

SMART FACTORY

Industry 4.0

— powered by  **BERNSTEIN** —

DETECT.PROTECT — Connect.

Produktübersicht

Product overview

Unser Service für Ihre Smart Factory

Our service for your Smart Factory

Zum Fuße des Kaiser Wilhelm Denkmals in Porta Westfalica gründete Hans Bernstein 1947 die Firma „BERNSTEIN Spezialfabrik für Schaltkontakte“. Heute beschäftigt die ostwestfälische BERNSTEIN AG mehr als 500 Mitarbeiter in 10 Ländern und wird als international tätiges Familienunternehmen bereits in 3. Generation geführt. Als einer der weltweit maßgeblichen Anbieter für industrielle Sicherheits- und Gehäusetechnik fasst BERNSTEIN diese Kompetenzen in den Geschäftsbereichen DETECT und PROTECT zusammen. Mit seinen Lösungen unterstützt das Unternehmen seine Kunden bei der Umsetzung ihrer Smart Factory im Zuge einer Industrie 4.0. Das Produktportfolio erstreckt sich von Schaltern, Sensoren und Gehäusen über Tragsysteme und Bedienterminals bis hin zu Systemlösungen zur Bedienung und Absicherung ganzer Maschinen und Anlagen. Insbesondere kundenspezifische Lösungen gehören zur Stärke der BERNSTEIN AG, die wir von der Idee über die Beratung, Entwicklung, Bearbeitung und Realisierung aus einer Hand umsetzen. Ein Service, der uns von anderen unterscheidet und unsere Kunden den entscheidenden Schritt weiterbringt.

At the base of the Kaiser Wilhelm Memorial in Porta Westfalica, Hans Bernstein founded the company “BERNSTEIN Spezialfabrik für Schaltkontakte” in 1947. Today, the BERNSTEIN AG employs more than 500 people in 10 countries and is managed as an internationally active family business in its 3rd generation. As one of the world’s leading suppliers of industrial security and enclosure technology, BERNSTEIN combines these competencies in the DETECT and PROTECT business areas and supports its customers in implementing their Smart Factory in the course of an Industry 4.0. The product portfolio ranges from switches, sensors and housings to suspension systems and operator terminals to system solutions for operating and safeguarding entire machines and plants. Customer-specific solutions in particular are one of the strengths of BERNSTEIN AG, which we implement from the initial idea to consulting, development, processing and implementation from a single source. A service that distinguishes us from others and takes our customers a decisive step further.

Blick auf die Weser in Porta Westfalica – der „Westfälischen Pforte“ zwischen Weser- und Wiehengebirge

View of the Weser in Porta Westfalica – the “Westphalian Gate” between the Weser and Wiehen Mountains

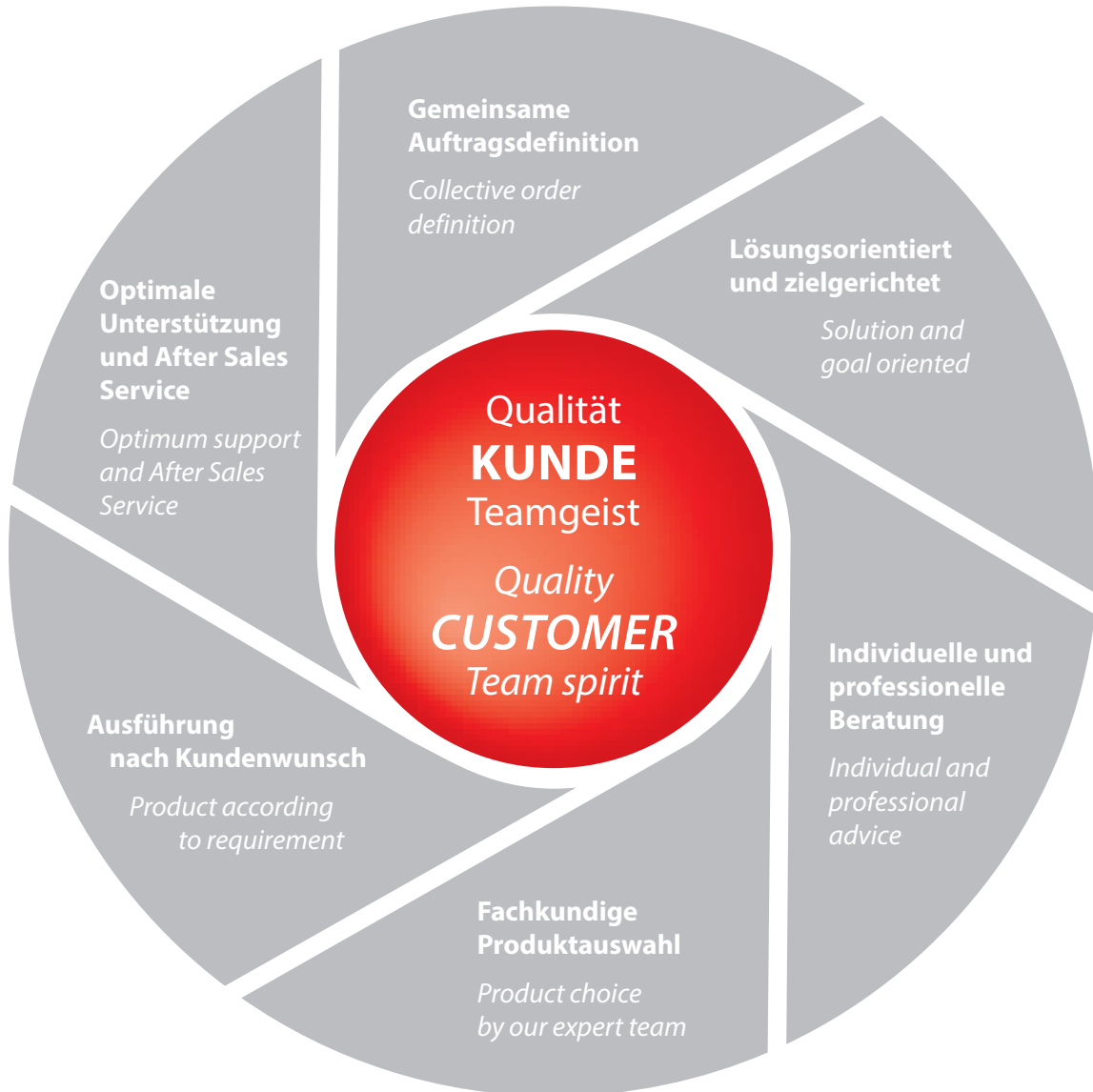

Die zwei Geschäftsbereiche **DETECT und PROTECT**

Um als international tätiges Familienunternehmen immer am Puls der Zeit und des Marktes zu sein, entwickeln wir uns technologisch und strategisch immer weiter.

Mit den zwei Bereichen DETECT und PROTECT definiert BERNSTEIN seine Kompetenzen aus den Bereichen Sicherheitstechnik und Gehäusetechnik. Denn so individuell wie die Anforderungen unserer Kunden sind auch unsere Produkte.

Dabei zielt das vielfältige Produktportfolio aus individuellen Schaltern, Sensoren, Gehäusen und Tragsystemen darauf ab, den Industrie 4.0 Prozess in Betrieben weiter voranzutreiben und die Umsetzung einer sicheren Smart Factory zu unterstützen.

Vereint unter dem Dach der Marke BERNSTEIN lassen sich die Bereiche DETECT und PROTECT im Sinne kundenspezifischer Lösungen auch miteinander verbinden – getreu unseres Mottos



The two business units **DETECT and PROTECT**

As an internationally active family business, we are always at the cutting edge of technology and strategy.

With the two business units, DETECT and PROTECT, BERNSTEIN defines its competencies in the fields of safety and enclosure technology – because our products are as individual as our customers' requirements. The extensive product range of individual switches, sensors, enclosures, operator terminals and suspension systems is aimed at further advancing the industry 4.0 process in companies and supporting the implementation of a secure smart factory.

United under the umbrella of the BERNSTEIN brand, the DETECT and PROTECT areas can also be combined in the sense of customer-specific solutions – true to our motto

DETECT. PROTECT — Connect.

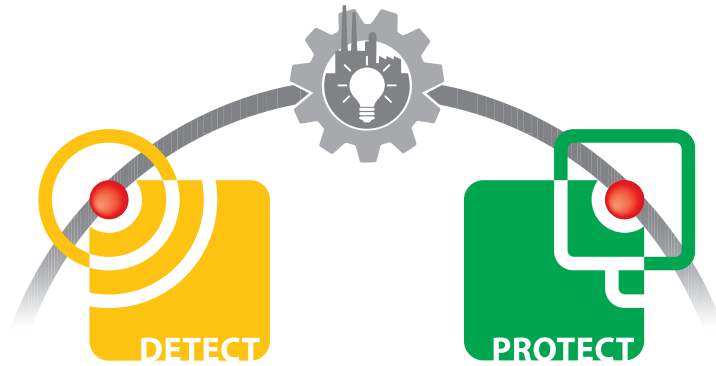

SMART FACTORY

Industry 4.0

— powered by  **BERNSTEIN** —

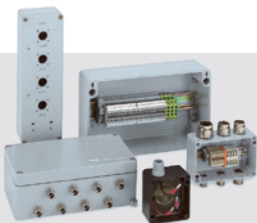

UNSERE PRODUKTE — OUR PRODUCTS



SEU-1/0-T45...

SRF-5

SEU-1/0-T45...

SRF-5

SEU-4

SCR P

SMART Safety System



reddot award 2018
winner



SRF



MAK 42



MAK 52



MAK 53

Berührungslose Sicherheitstechnik Contactless safety technology



C2



Ti2



I49



M49



IN65



Bi2



IN73

Isolierstoffgekapselte Positionsschalter

Double insulated position switches



SK



SKT



SKI



SKC



SLC

Sicherheitsschalter mit getrenntem Betätiger

Safety switches with separate actuator

UNSERE PRODUKTE — OUR PRODUCTS



MN78

D

GC

SN2

Metallgekapselte Positionsschalter

Metal-enclosed position switches



IN73 RP

SR

SRM

SRO

SI2

Seilzugschalter

Rope pull switches



SHS3



SHS3Z



SCR



SCR DI



SCR P

Sicherheitsschaltcharniere
Safety hinge switches

Sichere Auswertungen
Safety evaluation devices



F1

F2

FS

F2 UN

F3 UN

Fußschalter
Foot switches

UNSERE PRODUKTE — OUR PRODUCTS



Magnetsensoren
Magnetic sensors

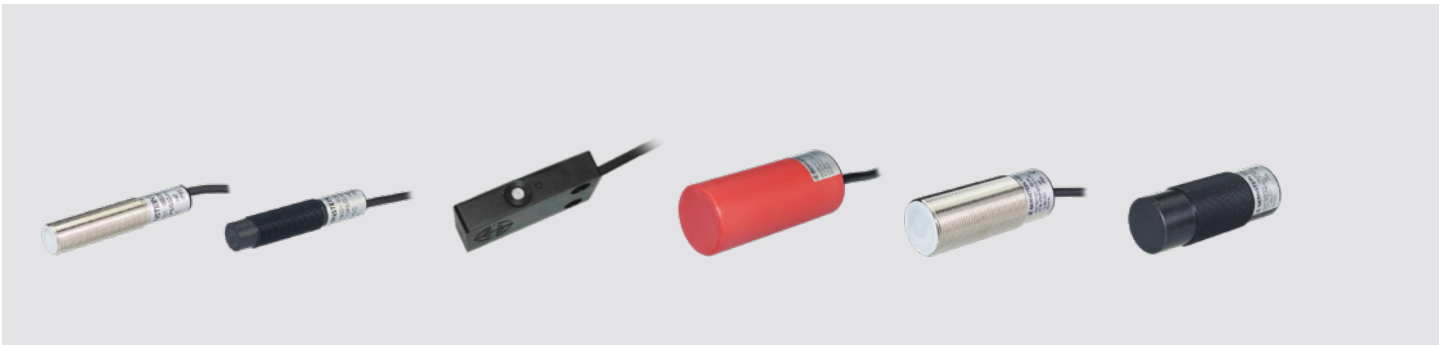

Kapazitive Sensoren
Capacitive sensors



Induktive Sensoren
Inductive sensors

UNSERE PRODUKTE — OUR PRODUCTS



CC-5000
next

Aluminium-Bediengehäuse
Aluminium control enclosures



CC-3000

Modulares Bediengehäuse
Modular control enclosure



CC-4000/ CC-4000 SL

Modulares Bediengehäuse
Modular control enclosure



Zubehör: Tastaturschubfach
Accessories: Keyboard drawer



BERNSTEIN Hygienetechnik
BERNSTEIN hygiene technology

www.bernstein-hygienetechnik.eu

Desinfektionssäule / Kundenzählung
Disinfection column / Customer Counting



CS-4000
next

Freistehende Standsäule
Free-standing column

UNSERE PRODUKTE — OUR PRODUCTS



CS-480 B.flex

Tragsystem
Suspension system



Aluminium-Tragsystem
Aluminium suspension system



Aluminium-Tragsystem
Aluminium suspension system

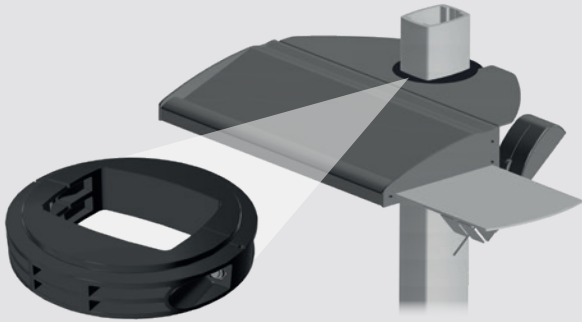

ergo.slide

Höhenverstellung
Height adjustment

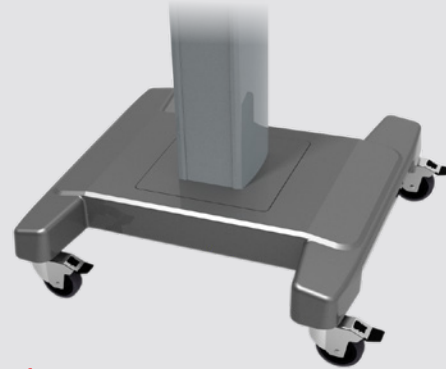

flex.base

Die flexible Standfußlösung
The flexible stand



CS-2000 System 80

Tragsystem
Suspension system



CS-480

Edelstahl-Tragsystem
Stainless steel suspension system

UNSERE PRODUKTE — OUR PRODUCTS

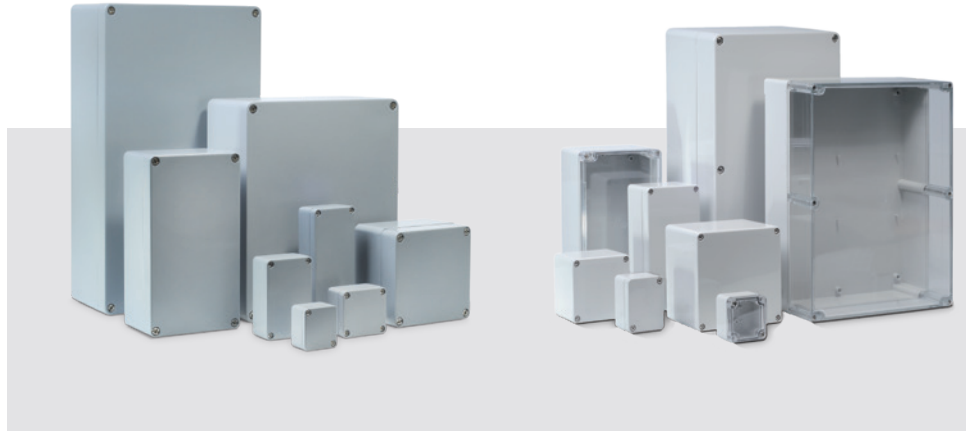

Standardgehäuse

Standard enclosures

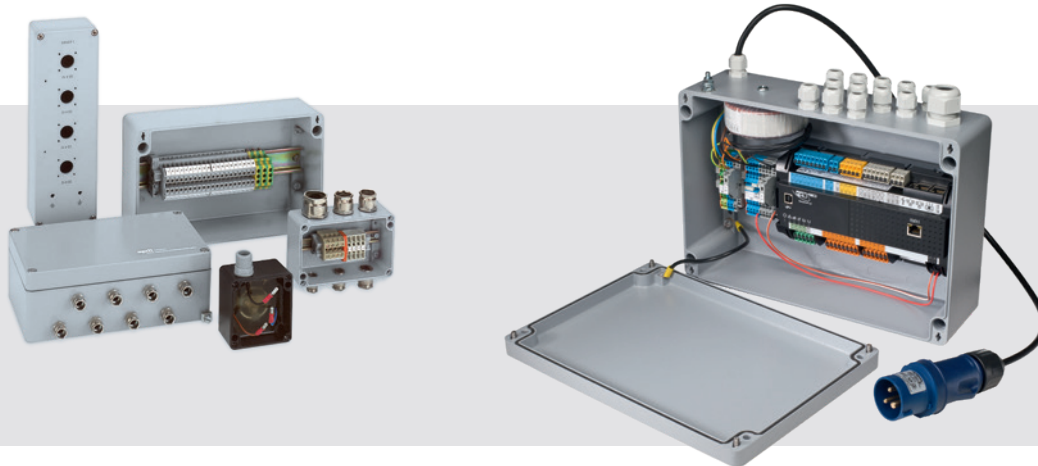

Bearbeitete Standardgehäuse

Machined standard enclosures

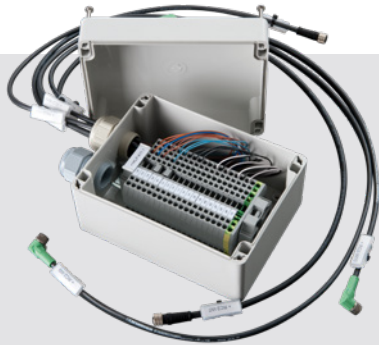
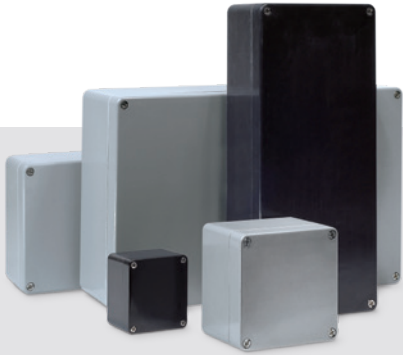

Bestückte Standardgehäuse
Assembled standard enclosures



Kundenspezifische Systemlösungen
Customised specific system solutions

Weltweit vor Ort
Mit Sicherheit immer für Sie da
Worldwide on site Always there for you

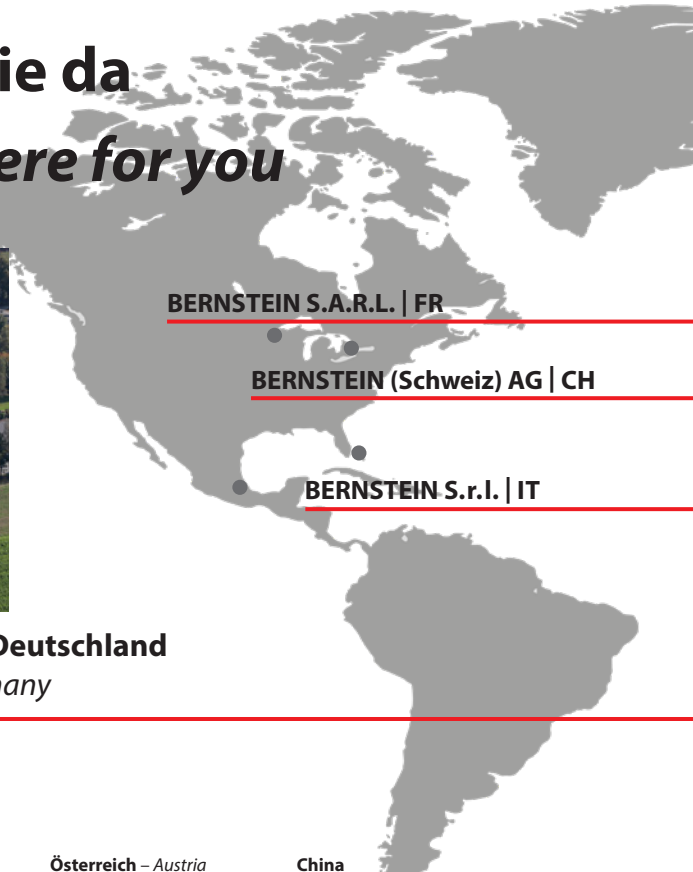

BERNSTEIN S.A.R.L. | FR

BERNSTEIN (Schweiz) AG | CH

BERNSTEIN S.r.l. | IT

BERNSTEIN AG – Headquarter und Logistikzentrum Deutschland
Headquarters and Logistics centre Germany

Kontakt

Contact

**International Headquarters
BERNSTEIN AG**

Hans-Bernstein-Str. 1
32457 Porta Westfalica
Tel. +49 571 793-0
info@bernstein.eu
www.bernstein.eu

Dänemark – Denmark

BERNSTEIN A/S
Tel. +45 7020 0522
info.denmark@bernstein.eu
www.bernstein.dk

Frankreich – France

BERNSTEIN S.A.R.L.
Tel. +33 1 64 66 32 50
info.france@bernstein.eu
www.bernstein.fr

Italien – Italy

BERNSTEIN S.r.l.
Tel. +39 035 4549037
sales@bernstein.it
www.bernstein.it

Großbritannien – Great Britain

BERNSTEIN Ltd
Tel. +44 1922 744999
sales@bernstein-ltd.co.uk
www.bernstein-ltd.co.uk

Österreich – Austria

BERNSTEIN GmbH
Tel. +43 2256 62070-0
office@bernstein.at
www.bernstein.at

Schweiz – Switzerland

BERNSTEIN (Schweiz) AG
Tel. +41 44 775 71-71
info.schweiz@bernstein.eu
www.bernstein-schweiz.ch

China

**BERNSTEIN Safe Solutions
(Taicang) Co., Ltd.**
Tel. +86 512 81608180
info@bernstein.asia
www.bernstein.asia

BERNSTEIN Ltd | UK

BERNSTEIN A/S | DK

BERNSTEIN GmbH | AT

www.bernstein.eu/kontakt

www.bernstein.eu/en/contact



BERNSTEIN Kft. Ungarn
BERNSTEIN Kft. Hungary



**BERNSTEIN Safe Solutions
(Taicang) Co., Ltd. | China**



DETECT

**We make
safety happen.**



PROTECT

**We keep your
visions safe.**